



ZRF RITEC SIA

**LARGE VOLUME HEMISPHERICAL
NUCLEAR RADIATION DETECTOR**

Model CZT/500

User Manual

CONTENTS

1. INTRODUCTION	3
2. SPECIFICATION	4
3. DESIGN FEATURES	5
4. SAFETY AND PRECAUTION	6
5. THEORY OF THE HEMISPHERICAL DETECTOR OPERATION	7

ILLUSTRATION

Fig. 1. Model CZT/500	3
Fig. 2. Spectrum of ^{137}Cs measured with CZT/500	4
Fig. 3. Design features of CZT/500	5
Fig. 4. Cross sectional view of a hemispherical detector showing the drift of electrons toward a positive "point" electrode and the resulting induced charge pulse. The majority of the induced pulse arises from electrons originating in the cross-hatched region of the hemisphere	7
Fig. 5. Appearance of a quasi-hemispherical detector	7

1. INTRODUCTION

The CZT/500 is a nuclear radiation detector based on CADMIUM ZINC TELLURIDE - CdZnTe, a large bandgap semiconductor material having a high atomic number and high density, which makes these detectors one of the most sensitive small size room temperature operation detectors.

The CZT/500 is spectrometric detector intended for gamma radiation registration in a range of an energy registered more than 60 keV.

Outward appearance of the CZT/500 is shown in fig.1.



Fig. 1. Model CZT/500.

2. SPECIFICATION

Basic

- detector type CdZnTe
- detector geometry..... quasi - hemispherical
- detector sensitive volume 500 mm³

Performance (at operation temperature +22 °C)

- energy resolution (FWHM) at 662 keV line 2,5 %
- peak-to-Compton ratio at 662 keV line ≥4,0
- bias voltage requirements
 - detector high voltage..... ≤ 1500V
 - detector high voltage polarity positive
- Range of recommended operation temperature 0 to 50°C

Dimensions

- diameter 23 mm
- length (without connector) 33 mm
- distance between a top plane of the housing cover
and sensitive surface of the detector 7±0,5 mm
- input window thickness (aluminum)..... 1,2±0,2 mm

Connector..... BNC type

Typical spectrum of ¹³⁷Cs measured with CZT/500 is shown in fig. 2

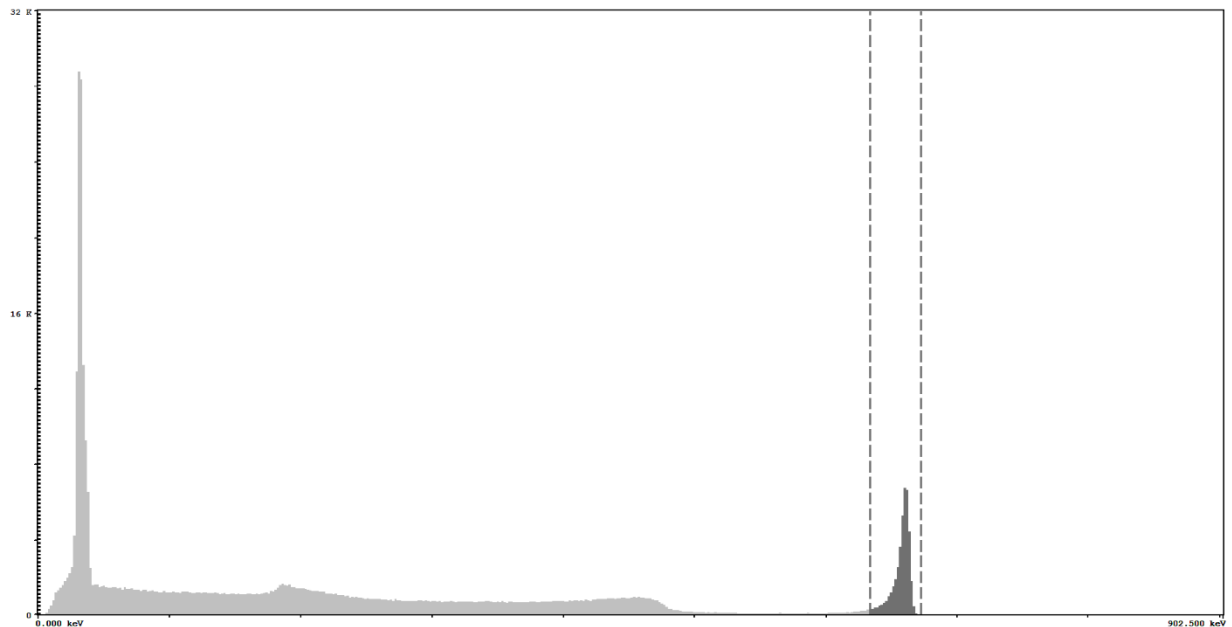

Fig. 2. Spectrum of ¹³⁷Cs measured with CZT/500.

3. DESIGN FEATURES

The detectors consist of CdZnTe detector, watertight housing and BNC connector.

Detectors can be used with low-noise charge-sensitive preamplifiers having a BNC-type input connector, for example, a miniature preamp Model PA101C.

The CZT/500 design features are shown in fig. 3.

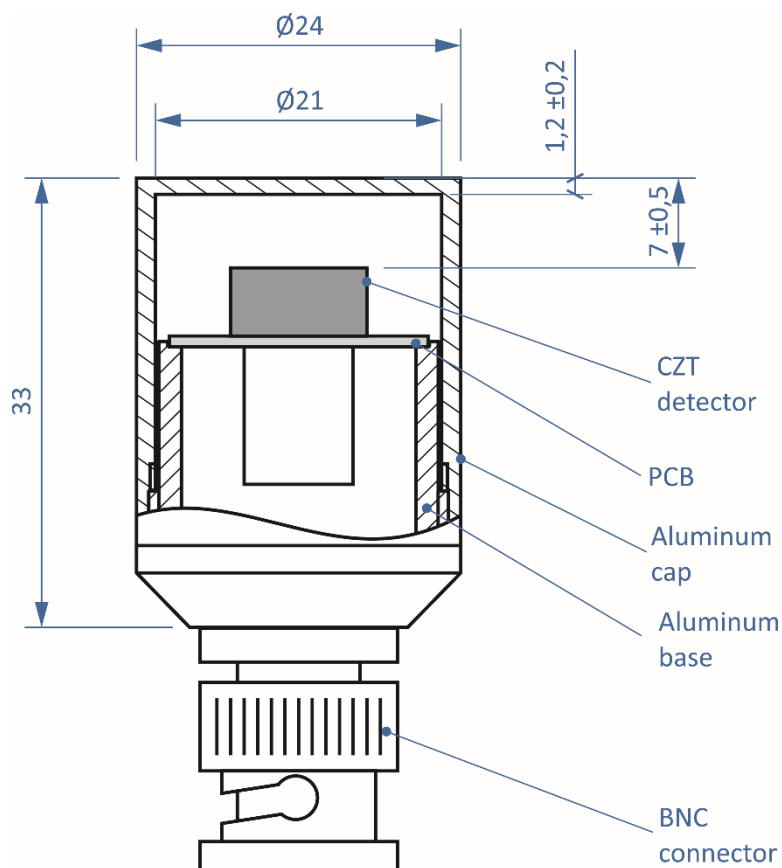

Fig. 3. Design features of CZT/500.

4. SAFETY AND PRECAUTION

Equipment Precautions:

- The CZT/500 must be connected to the **POSITIVE** high voltage supply.
- The detector housing is fragile and should not be strongly squeezed.
- When possible, use radiation shield and (or) collimator or maintain the detectors a distance from strong neutron-gamma sources for prevention of detector and connector's insulator radiating damages.
- Decontamination or cleaning of detectors can be carried out with water or other non-corrosive liquids.

Radiation Dose Caution:

- The detector should be routinely checked for contamination and decontaminated, if necessary, after use to avoid possibility of radioactive contamination.

5. THEORY OF THE HEMISPHERICAL DETECTOR OPERATION

The resolution of the wide band semiconductor detectors, such as CT or CZT detectors optimized by choosing a small hemispherical crystal geometry with a positive contact at the center of the flat surface and the outer spherical surface grounded (see fig. 4). The electric field is essentially radial and therefore much stronger near the positive contact. Assume first that only electron charge collection occurs with no appreciable electron carrier trapping. The pulse that is registered from a photoelectric event with a constant number of electrons produced would arise mainly from the induced charge from the electron carriers traversing the high field region. Even so, gamma photoelectric interactions in the lower field region (cross hatched) constitute the majority of the peak area (cross hatched) since this is where the majority of the detector volume resides. The electron carriers from throughout the detector volume drift toward the positive electrode reaching their highest velocity near the positive electrode. The electron collection time is less than $0.5 \mu\text{s}$.



Fig. 4. Cross sectional view of a hemispherical detector showing the drift of electrons toward a positive “point” electrode and the resulting induced charge pulse. The majority of the induced pulse arises from electrons originating in the cross-hatched region of the hemisphere.

The pulse height from a gamma interaction does not appreciably depend on holes collection due both to the hemispherical geometry and the short pulse shaping time. This is fortunate since hole drift velocities are an order of magnitude smaller causing hole collection time to be typically $5 \mu\text{s}$ and hole trapping to become important. The hole pulse height contribution tends to be very small since few holes traverse the high field region drifting rather toward the negative hemispherical surface electrode, thus a far smaller pulse is induced and the pulse shaping time of about $1 \mu\text{s}$ “clips” this pulse contribution well before it reaches its full height. The $1 \mu\text{s}$ shaping time does no clipping to the electron collection signal. The CZT or CdTe detector resolution is limited primarily by trapping of holes due to impurities and inhomogeneities in the crystal.

Manufacturing of detectors with ideal hemispherical geometry is labor-consuming process. Therefore, in detection units are used quasi-hemispherical detectors. The appearance of such detectors is shown in fig. 5. Researches have shown that the replacement of ideal hemispherical geometry of the detector on quasi-hemispherical a little bit worsens the spectrometer performance.

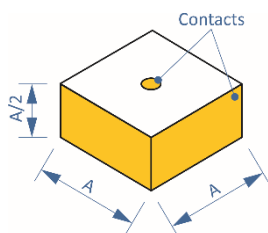

Fig. 5. Appearance of a quasi-hemispherical detector.